

Tray Inserter

EMERALD
AUTOMATION

International Automation & Innovation

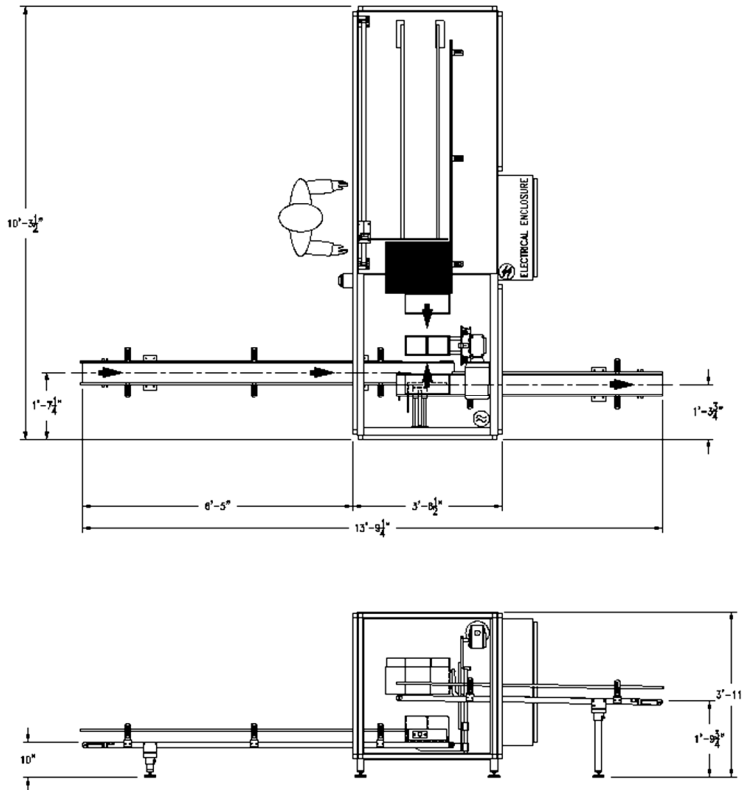

The **Tray Inserter** selects one or two smaller trays, erected by a Trayformer, and inserts them into a sleeve.

Emerald Automation integrates a diverse yet practical approach to machinery design to provide rugged construction complemented with state-of-the-art technologies. Whether it's developing a machine to supply a new market, or rebuilding existing machines with new technology, we will work to provide our customers with solutions that meet their individual needs.

www.emeraldautomation.com

FEATURES

- ◆ Allen Bradley PLC controls
- ◆ Up to 20 sleeves/min (dependent on size)
- ◆ HMI for Setup/Alarming/Diagnostics
- ◆ Extended magazines for high capacity availability
- ◆ Ethernet communications
- ◆ Easy to use operator interface with 'On Board' help screens
- ◆ "Tool-less" Changeover

CONSTRUCTION

- ◆ Heavy-duty frame & manufactured parts
- ◆ Powder coating finish
- ◆ UL 508A Listed Enclosure
- ◆ Easy-access Lexan guarding
- ◆ Integrated safety guarding with separate E-Stop
- ◆ OSHA approved safety design

OPTIONS

- ◆ Quick-disconnect field devices

Emerald Automation

9228 W Clearwater Drive
Kennewick, WA 99336

Phone:

509.783.1369

Email:

sales@emeraldautomation.com